



**User manual
Roof structure profile kit
Art. 155.414
UNIROOF AT/ST**

**Leister Technologies AG
Galileo-Strasse 10
CH-6056 Kaegiswil/Switzerland
Tel. +41 41 662 74 74
Fax +41 41 662 74 16
www.leister.com
sales@leister.com**



We know how.

Application only in Europe allowed



Of patent
Reasons is the kit in North
America not be used!

Easy welding of profiles



welding with 30-40
mm UNIROOF nozzle

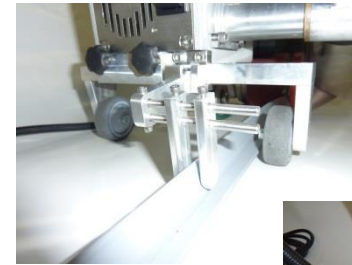

Step 1: assemble rollercover

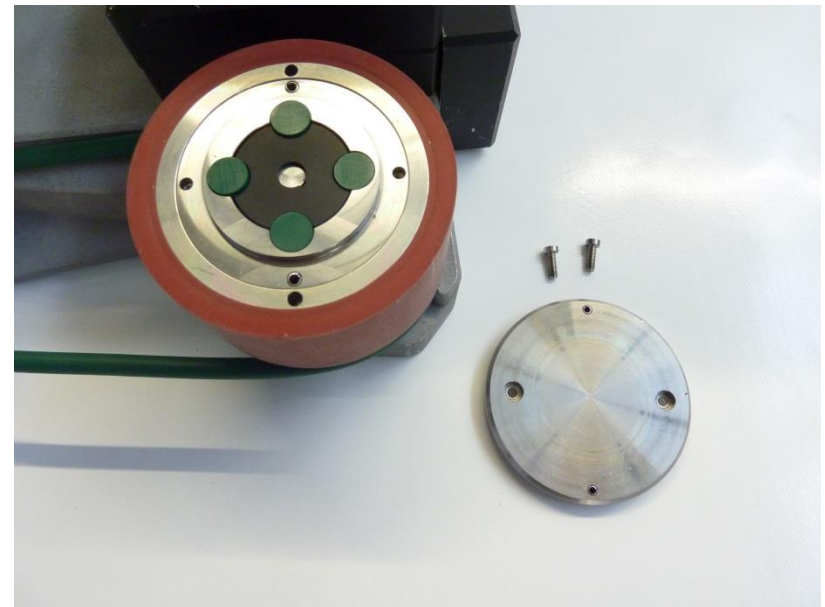
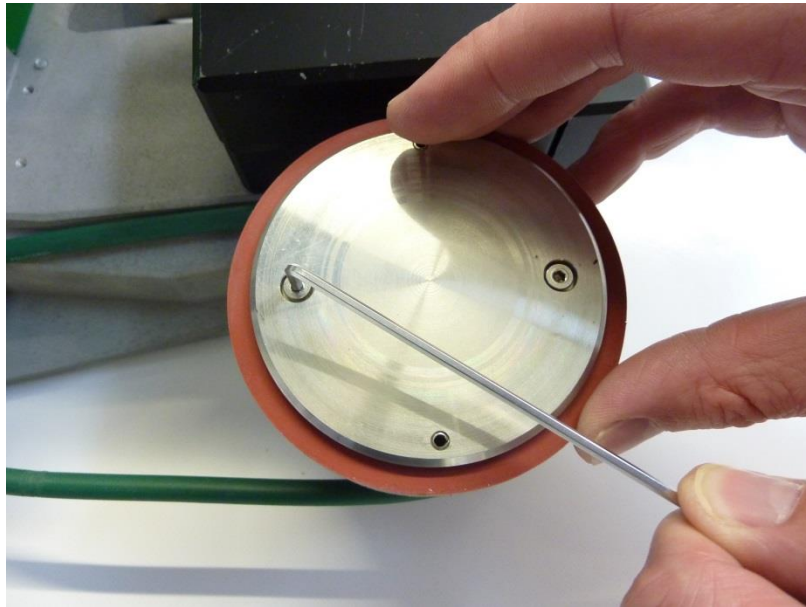

Step 2: assemble guidingroller

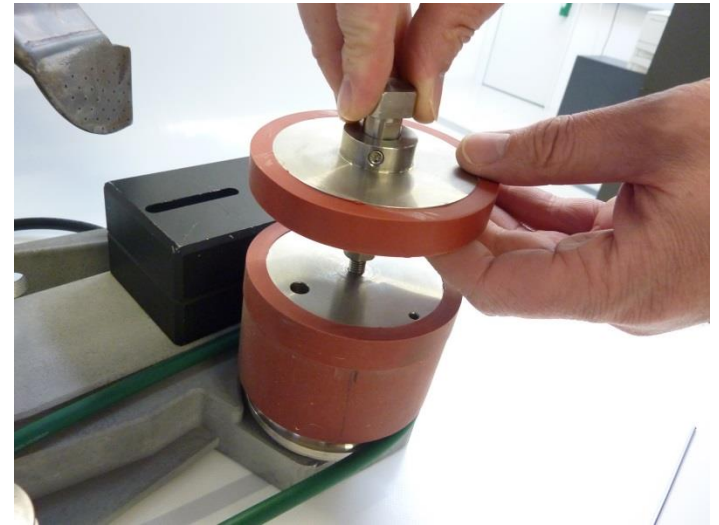
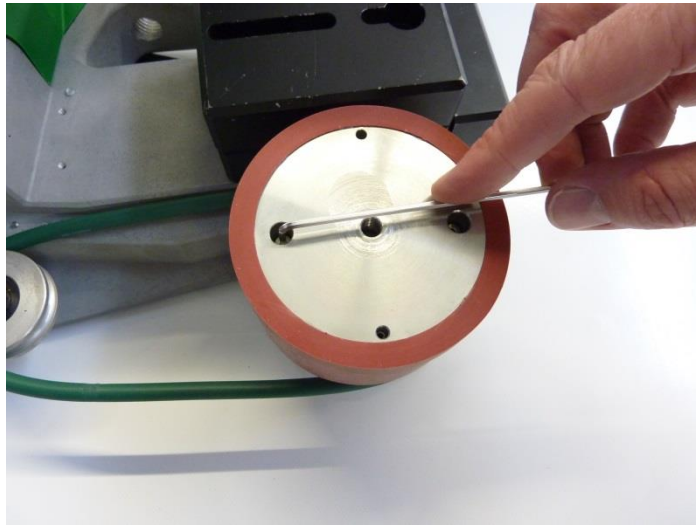
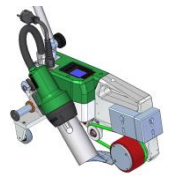

Step 3: assemble flange for pivot axis

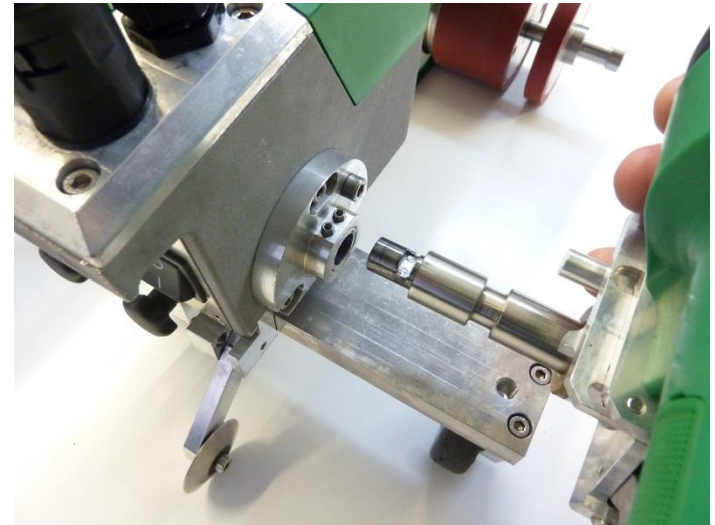

Step 4: assemble flange for pivot axis

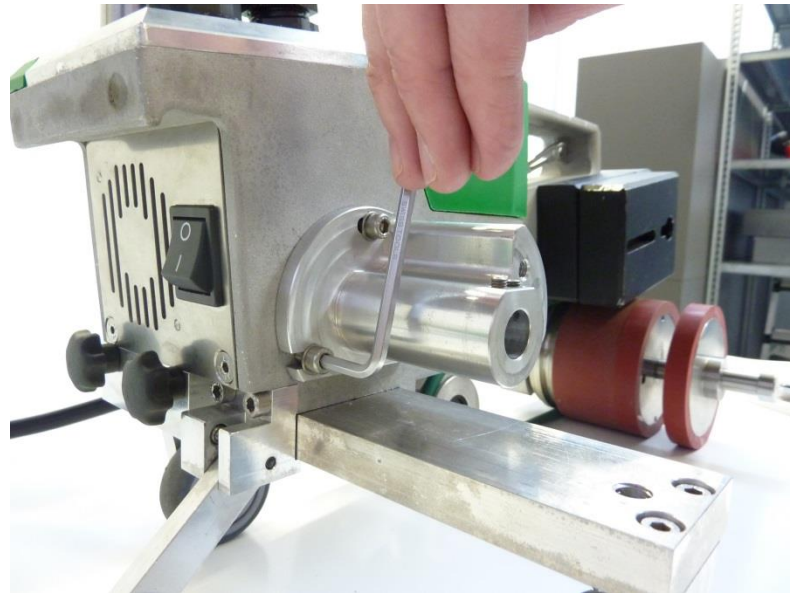

Step 5: change guidingroller

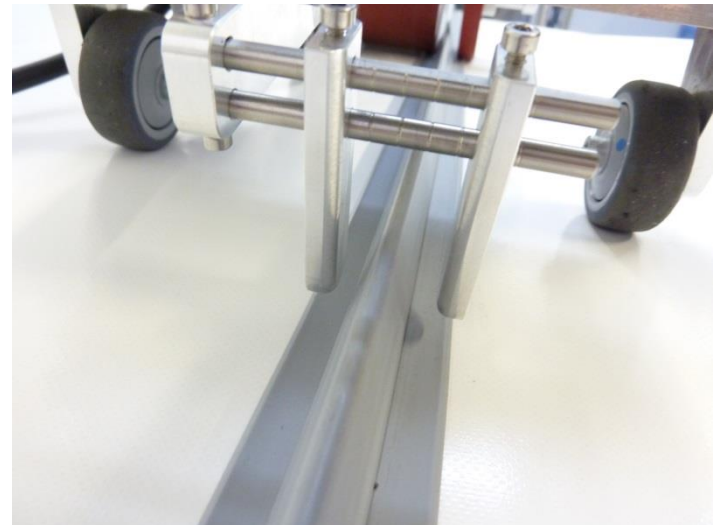
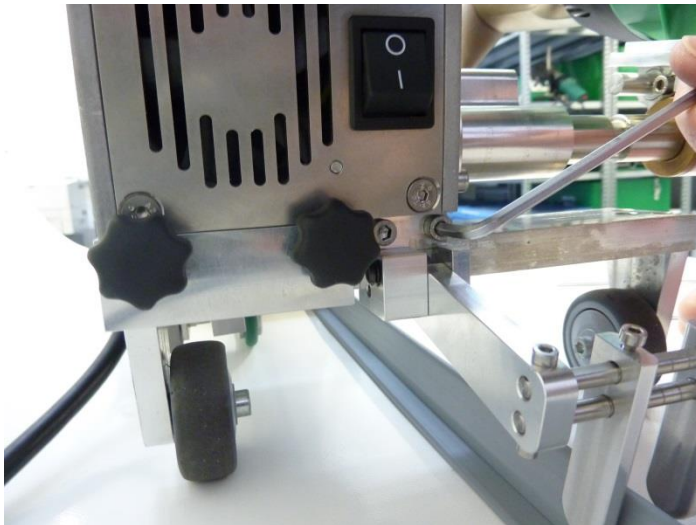
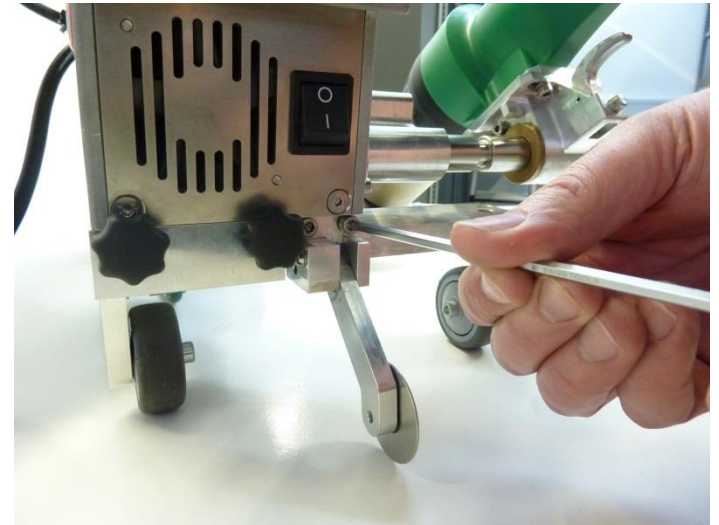
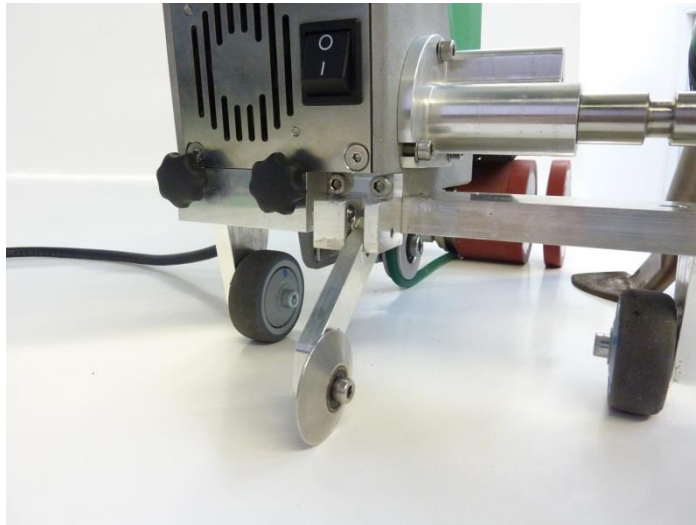
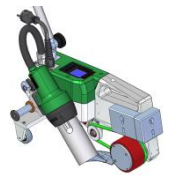

Step 6: ajust pressure roller

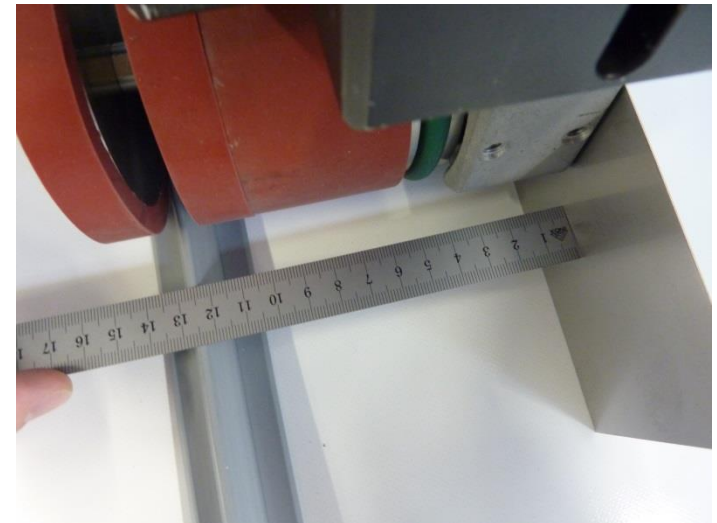
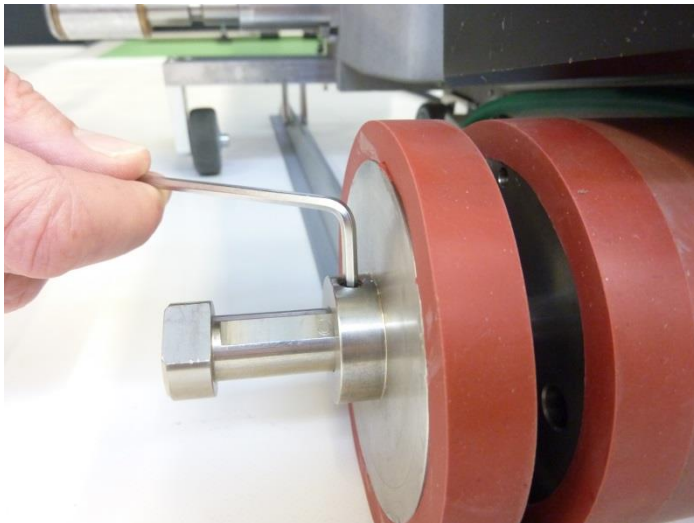
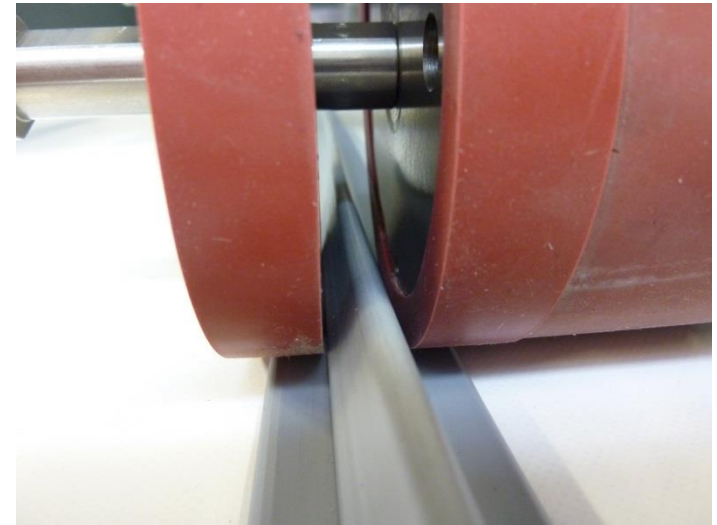
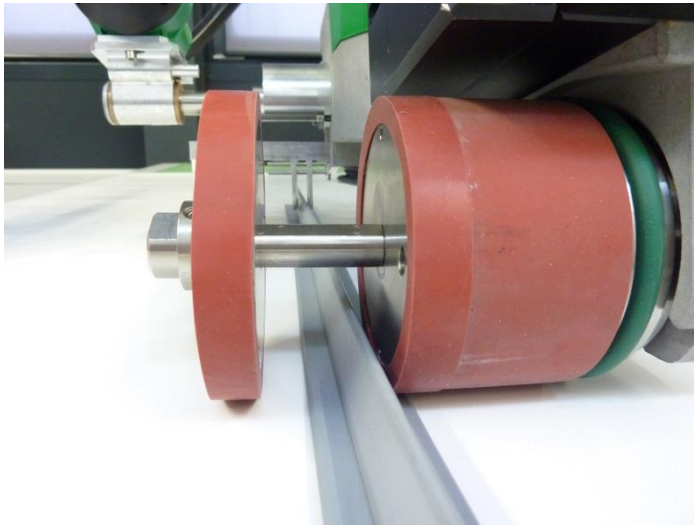

Step 7: ajust guide

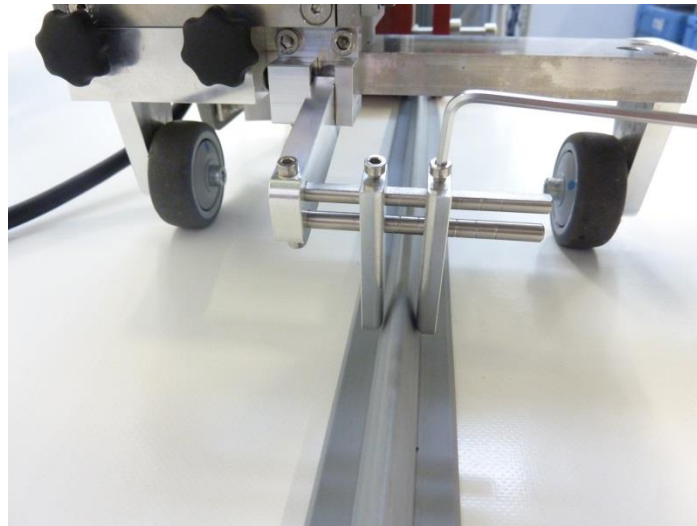
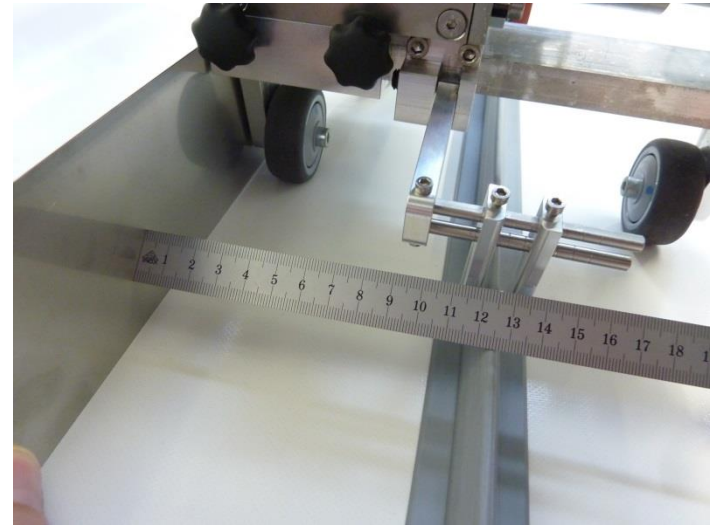
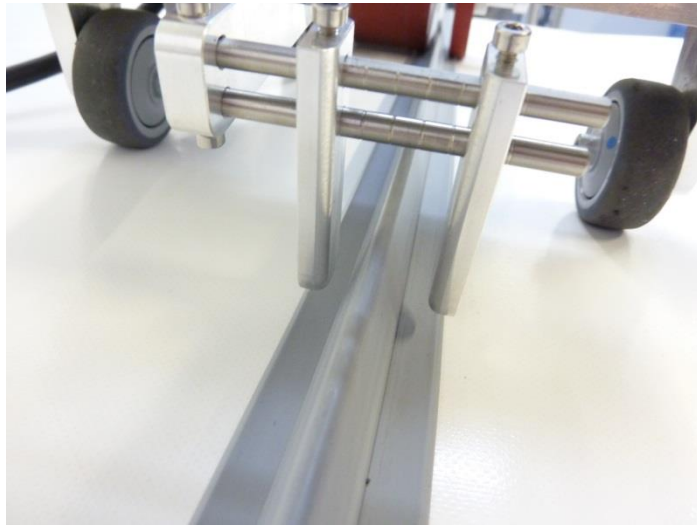
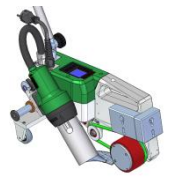

Step 8:

change nozzle from 40mm to 30mm

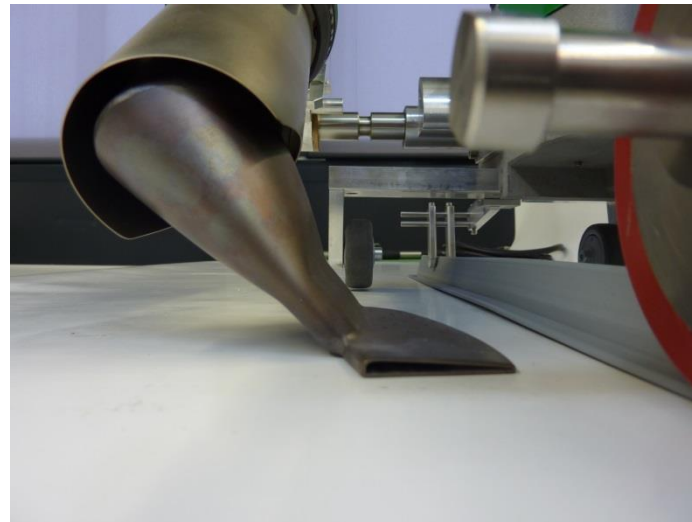
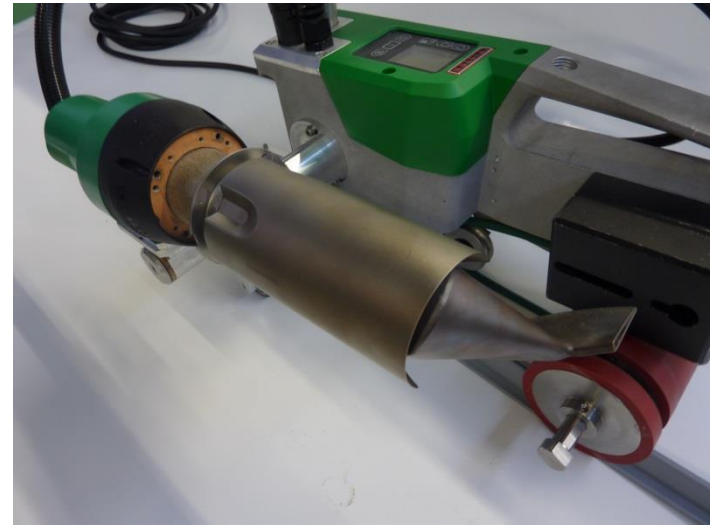
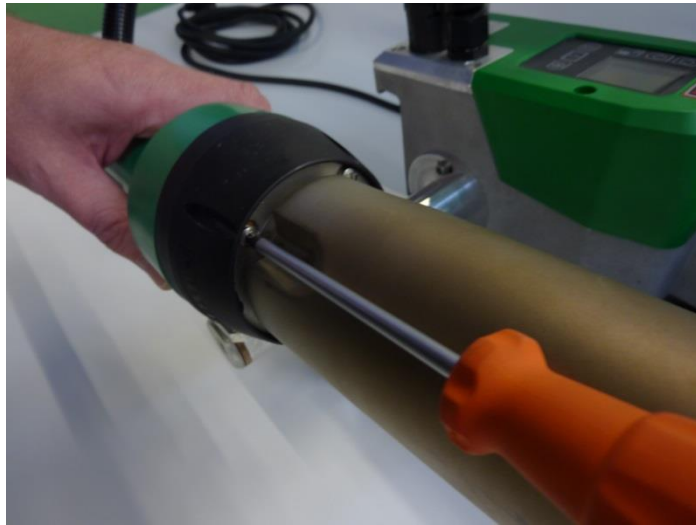

Step 9: ajust nozzle

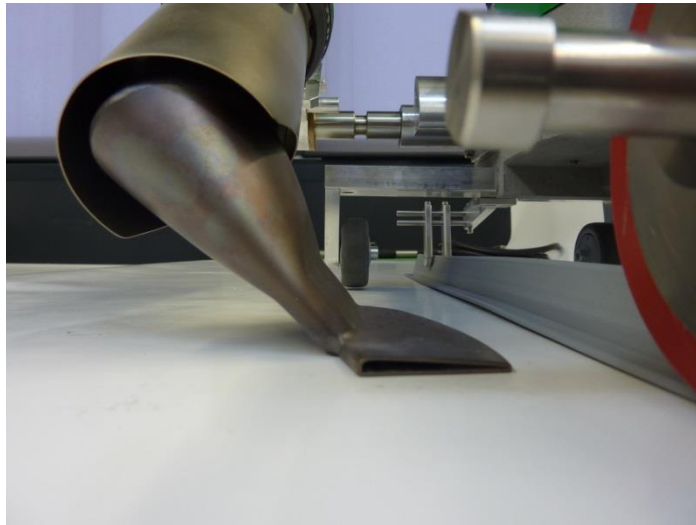

adjust nozzle flat

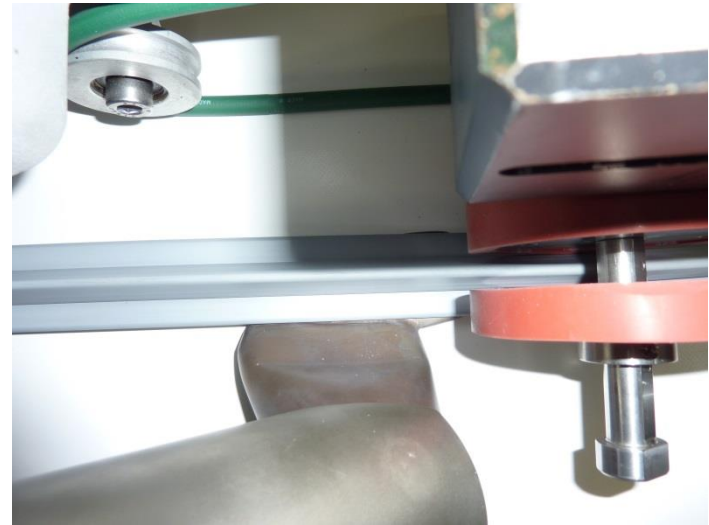

Adjust nozzle centered on
structural profile

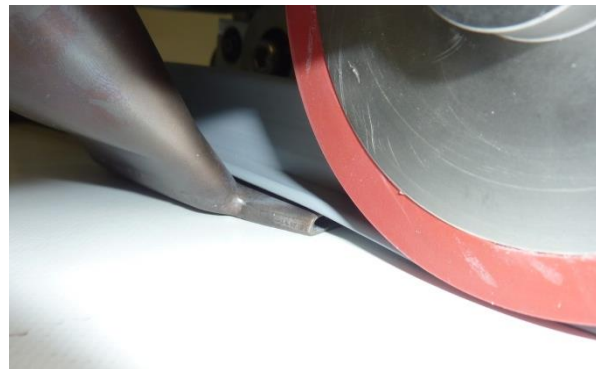

Step 10: Setting the transport axis

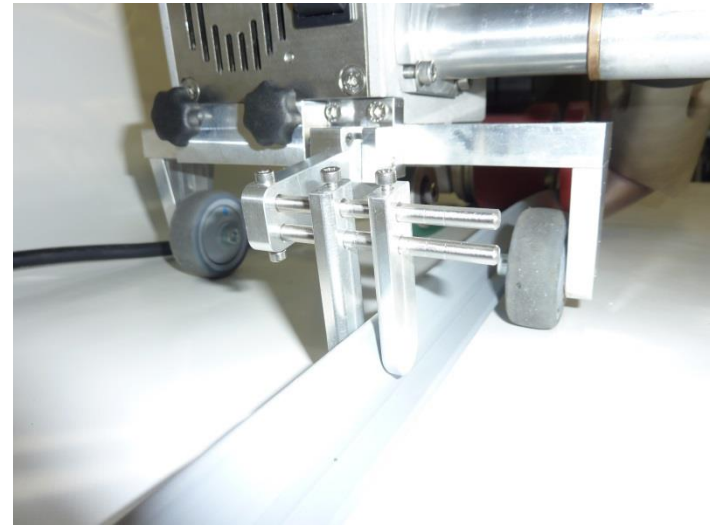
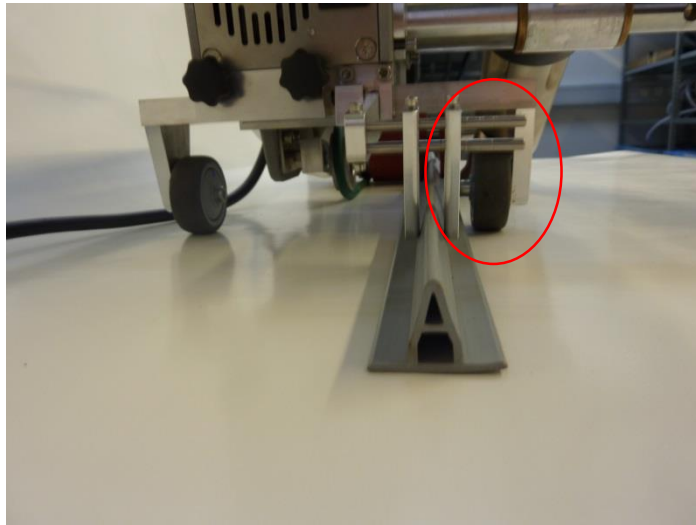

Setting the Right wheel as close to the structure profile.

the recommended transport axis is the 300mm axis.

assembly drawing

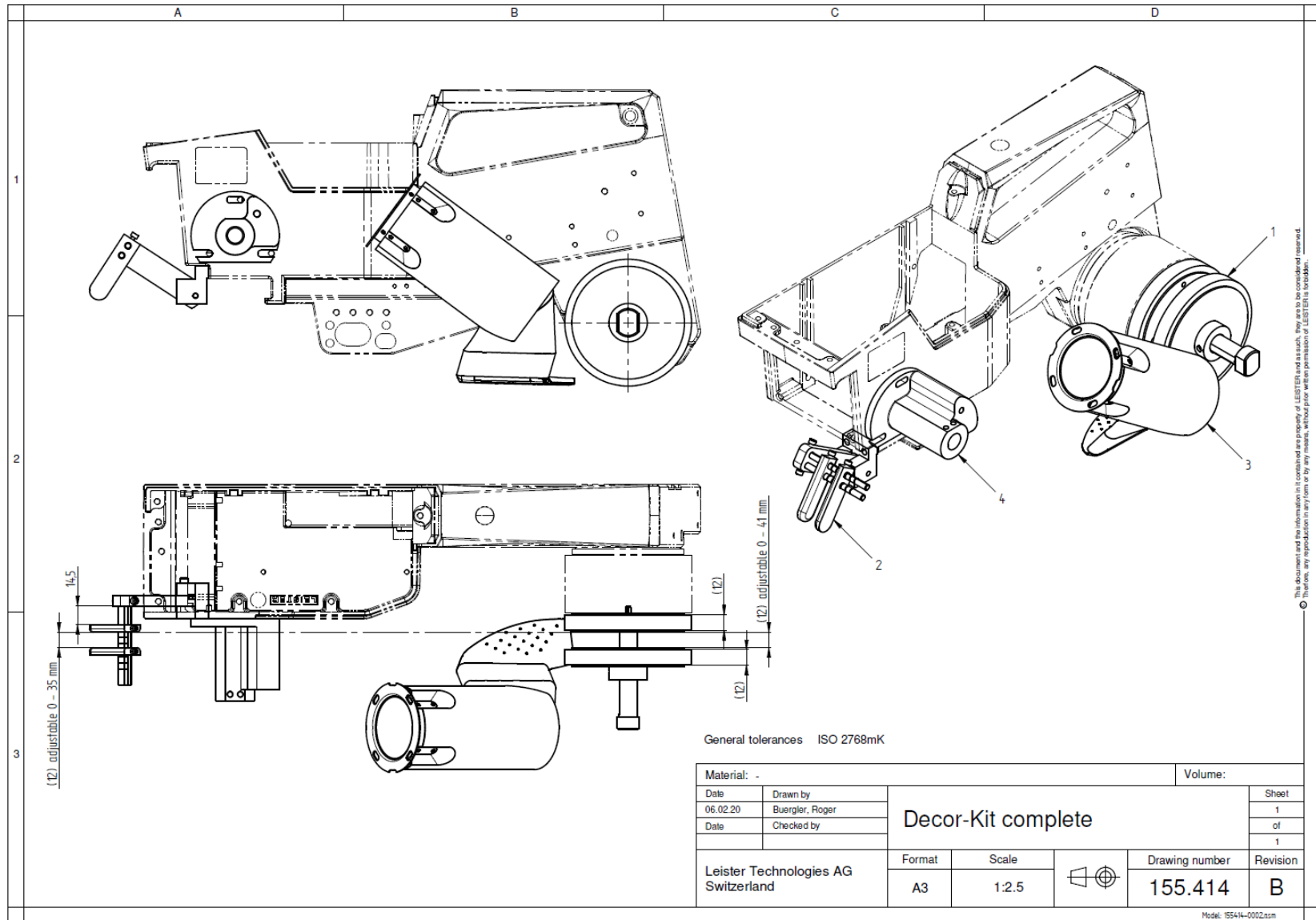

This document and the information it contains are property of LEISTER and as such, they can be considered reserved. Therefore, any reproduction in any form or by any means, without prior written permission of LEISTER is forbidden.

Part list

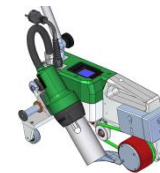

Pos.	Pcs	Number	Part
1	1	153.701	Pressure roller complete
2	1	153.262	Decor-Kit guiding
3	1	155.326	Overlap welding nozzle
4	1	153.015	Flange

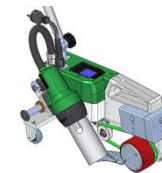

Your authorised Service Centre is:

Leister Technologies AG
Galileo-Strasse 10
CH-6056 Kaegiswil/Switzerland
Tel. +41 41 662 74 74
Fax +41 41 662 74 16
www.leister.com
sales@leister.com

BA Dach Strukturprofil-Kit / 02.2016
Artikel Nr. 155.895